

## Description

This robust design is capable of 13A at 125°C without a heatsink\* and is short circuit protected, load dump protected, and reverse battery protected and made to work in the harshest of conditions. This relay will work in 12VDC and the 24VDC nominal systems and is rated to over 2.5 million cycles.

## Features

- Unit has short circuit protection but should be externally fused with 15A ATM/ATO/ATC fuse to protect against over-current
- Unit has reverse battery protection (load remains off when battery is reversed)
- Unit has loss of ground protection (load remains or shuts off with a loss of ground)
- UL recognized options available
- RoHS, Reach, Conflict Free Compliant

\*minimal airflow is required if the unit is not mounted to a heatsink

## Specifications

### Output Specification

Operating Voltage	9-32 VDC
Maximum Jump Start Voltage	48 VDC
Maximum Continuous Load Current	13A
Minimum Load Current	1 mA
Max Surge Current	28A (15 Seconds), 40A (1 millisecond)
Maximum Off-State Leakage Current	Less than 1 mA

### Input Specification

Control Voltage Range	9-32 VDC (12V - 24V nominal)
Minimum Turn-On Voltage	7.5 VDC
Maximum Turn-Off Voltage	6.5 VDC
Nominal Input Impedance	1.66K ohms +/-10%
Minimum Input Current (typical)	18 mA

### General Specification

Operating Temperature	-40°C - 125°C
Storage Temperature	-55°C - 135°C
Weight (typical)	9.6 oz
Ingress Protection	IP66 and IP68
Electrical Cycle Life	2.5 million cycles (minimum) at maximum continuous load
Load Dump Protection	Us - 151V, Ri - 2 ohms, Td - 350 ms
Mating Connector	TE Connectivity AmpSeal 16 plug 4 position 14-18 AWG PN 776487-1 or equivalent
Mating Contact	TE Connectivity AmpSeal 14-18 AWG Gold Socket PN 776491-1 or equivalent

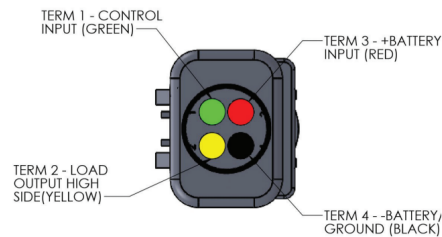
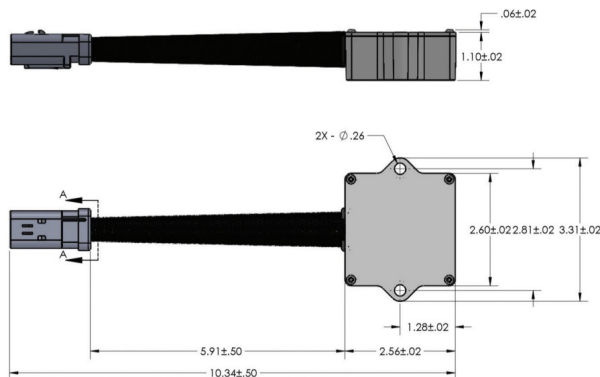

### Connector

TE Connectivity AmpSeal 16 receptacle 4 position 14-18 AWG PN 776488-1 or equivalent

### Contact

TE Connectivity AmpSeal 14-18 AWG Gold Pin PN 638112-1 or equivalent

- Unit does not protect against over-temperature (external fuse should be used)
- Input Signal should be controlled by a solid state or low bounce input

- Unit does not protect against over-temperature (external fuse should be used)
- Input Signal should be controlled by a solid state or low bounce input

